



ICBO Evaluation Service, Inc.

5360 WORKMAN MILL ROAD • WHITTIER, CALIFORNIA 90601-2299

A subsidiary corporation of the International Conference of Building Officials

EVALUATION REPORT

Copyright © 1999 ICBO Evaluation Service, Inc.

ER-4927

Issued September 1, 1999

Filing Category: DESIGN—Masonry (038)

CRIBLOCK RETAINING WALLS
RETAINING WALLS COMPANY
1531 GRAND AVENUE
SAN MARCOS, CALIFORNIA 92069

1.0 SUBJECT

Criblock Retaining Walls.

2.0 DESCRIPTION

2.1 General:

Criblock Retaining Walls are gravity retaining walls consisting of concrete grid members dry-stacked as a crib, with soil or rock backfilled within the crib cell.

2.2 Criblock Retaining Wall Grid Members:

The Criblock members are illustrated in Figure 1.

2.2.1 Front Stretchers: Horizontal front stretchers are reinforced with No. 4 reinforcing steel; are 6 inches (152 mm) wide, 4 inches (102 mm) high and 5 feet (1524 mm) long; and weigh 125 pounds (57 kg).

2.2.2 False Headers: False headers are unreinforced; are 10 inches (254 mm) wide, 4 inches (102 mm) high, and 9.5 inches (241 mm) long; and weigh 30 pounds (14 kg).

2.2.3 Headers: Headers are perpendicular to the wall face and are reinforced with No. 4 reinforcing steel. They are 9.5 inches (241 mm) high, 4 inches (102 mm) wide, and 4.5 feet or 5 feet (1372 mm or 1524 mm) long, and weigh from 115 to 135 pounds (52 to 61 kg).

2.2.4 Back Stretchers: Back stretchers are reinforced with No. 4 reinforcing steel; are 6 inches (152 mm) wide, 4 inches (102 mm) high, and 3 feet 9 inches (1143 mm) long; and weigh 95 pounds (43 kg).

2.3 Materials:

All reinforcing steel and deformed bars conform to ASTM A 616, Grade 60, with a minimum yield strength of 60,000 psi (413 MPa). Concrete members are cast using a dry-mix process that provides a minimum concrete compressive strength at 28 days of 3,250 psi (22.4 MPa) using Type II portland cement complying with ASTM C 150.

2.4 Design:

Criblock Retaining Walls are gravity retaining walls dependent on the cribwall weight and the angle of inclination to resist lateral earth pressure or other lateral forces. A soil investigation report, as noted in Section 1804 of the code, is required. The report must include soil properties (unit density, soil friction angles for an anticipated range of normal pressures, coefficient of friction between cribwall members and underlying soil, and coefficient of friction between cribwall members and soil backfilled within crib cells) for backfill soils,

retained excavation soils and foundation soils, as applicable. Lateral loads are determined by accepted geotechnical engineering procedures appropriate for the soil and geometric conditions specified for the wall, and must address the applicability of the Criblock Retaining Walls system, including applicability in seismically active areas. The effect of surcharges must be considered. The lateral soil pressure is determined using the Coulomb theory, with the angle of wall friction assumed to be two-thirds the angle of internal friction.

2.5 Structural Analysis:

Structural calculations based on accepted engineering principles, this report, and Section 2107 of the code must be submitted to the building official for each wall system, except where otherwise specified in this report.

The vertical frictional component of pressures due to retained soil is located at the centroid of the inclined plane of the wall-to-soil interface. Each cribwall must have a minimum safety factor of 1.5 against overturning and sliding. Maximum soil-bearing pressures at the toe and heel of the cribwall are limited to values provided in the soils report. The resultant of the soil-bearing pressure must occur in the middle-third of the cribwall base. When calculations distribute the soil-bearing pressure over the entire base width of the cribwall, the bearing pressure between the front and rear courses at the base is developed by friction between the soil within the cribwall cell(s) and the crib elements (stretchers and headers). Sliding resistance of the cribwall is based on friction between the concrete stretchers and underlying soil, and the shear capacity of the soil within the cribwall plug.

All contact surfaces of the units must be maintained in compression. The maximum compression stress under service load stress design is determined in accordance with Section 1926.3.1 of the code, with the wall designed to provide a minimum safety factor of 1.5 for sliding between cribwall elements. The stretcher-to-header connection is based on friction with a static coefficient of friction of 0.60. Internal analysis of the cribwall must include design of rear stretchers for lateral forces due to retained soil and soil confined within the cribwall cell, and for vertical forces due to gravity and arching action of the confined soil. Forces on front stretchers are similar to those on the rear stretcher, except lateral forces due to retained soil are resisted solely by the rear stretchers. Bottom courses of front, rear and middle stretchers must also be designed for upward loads due to moments imposed by lateral loads. Headers must be designed for the axial forces developed in connecting the front and rear stretchers. See Tables 1 and 2 for allowable heights and maximum bearing pressures.

2.6 Assembly:

The angle of wall inclination is 3:12 (horizontal:vertical) toward the backfill. Front stretchers are connected to a similar

Evaluation reports of ICBO Evaluation Service, Inc., are issued solely to provide information to Class A members of ICBO, utilizing the code upon which the report is based. Evaluation reports are not to be construed as representing aesthetics or any other attributes not specifically addressed nor as an endorsement or recommendation for use of the subject report.

This report is based upon independent tests or other technical data submitted by the applicant. The ICBO Evaluation Service, Inc., technical staff has reviewed the test results and/or other data, but does not possess test facilities to make an independent verification. There is no warranty by ICBO Evaluation Service, Inc., express or implied, as to any "Finding" or other matter in the report or as to any product covered by the report. This disclaimer includes, but is not limited to, merchantability.

grid of back stretchers with the headers. Stretchers are interlocked with the headers and assembled without mortar. The grids of back stretchers are parallel to the front stretchers. False headers are installed between the stretchers in the front and back grids as shown in Figures 2 and 3. The cribwall may be installed with one or more grids of stretchers parallel to, behind and connected to, the face grid of front stretchers by the interlocking headers. More than one grid of back stretchers forms a multiple-depth cribwall.

The crib between the front and back grid of stretchers must be filled either with free-draining rock or with well-compacted free-draining, nonexpansive soil, as specified by the wall design engineer. A layer of compacted backfill material must be placed behind the cribwall. Backfill material consists of either well-graded crushed rock that is at least 1 inch (25.4 mm) in diameter, or free-draining nonexpansive soil free of organic and deleterious materials and conforming to the gradation limits specified in AASHTO T-27. Where cohesive soil is used, backfill soil must be a mixture of cohesive and cohesionless soils. Backfill soils within and behind the cribwall are placed in layers having a maximum-1-foot (305 mm) loose-depth. Each layer is thoroughly compacted to a minimum 90 percent relative compaction in accordance with ASTM D 1557 or equivalent. Backfill consisting of rock less than 6 inches (152 mm) in diameter is dumped in place; care is necessary to minimize the dump height. Rocks exceeding 6 inches (152 mm) in diameter must be hand-placed. The alignment of the cribwall must be maintained during backfilling and compaction operations. A maximum 2¹/₂ courses of cribwall framing may be assembled before backfilling. Areas above and behind the cribwall are backfilled to the finished pattern shown on the project plans.

Drainage within and behind Criblock Retaining Walls must comply with recommendations of the soils engineer. Where the soil has poor drainage qualities, a continuous perforated subsoil drain of minimum-4-inch (102 mm) diameter is installed. A sufficient number of drainage outlets must be provided. Drainage above the cribwall must be collected and diverted using drainage interception ditches. Drainage of cribwalls is necessary to prevent hydrostatic-pressure buildup behind the cribwall, and to prevent any erosive flow of surface water down, through and over the wall face.

A bench excavation to sound material is necessary for the base of the cribwall. The depth must be at least 1 foot (305 mm) below the proposed finished ground level at the front face of the cribwall, or as shown on approved project plans. Cribwalls without a concrete footing need not be laid below the frost-penetration depth. The cribwall is placed directly on the base soil, unless the design requires the cribwall to be installed on a concrete footing designed by a civil or structural engineer. Details in this evaluation report are limited to application in areas outside groundwater. Footings in groundwater are contingent on appropriate soil and engineering analysis reports being submitted to the building official for approval.

The cribwall may be assembled in a curved layout with a minimum radius of 25 feet (7620 mm). For cribwalls having a curve radius of less than 100 feet (30 480 mm), stretchers are saw-cut, or special-length stretchers are furnished to provide

a maximum 1-inch (25.4 mm) gap between stretchers. Curved cribwalls must have a uniform angular change at each joint between stretchers so that the front face presents an even surface along the cribwall.

2.7 Special Inspection:

Special inspection during installation must be observed in accordance with Section 1701.5.7.1 of the code. The inspector's responsibilities include verifying:

1. Unit compliance with this evaluation report, including identification as noted in Section 2.8.
2. Foundation preparation.
3. Unit placement, including alignment and inclination.
4. Backfill placement and compaction.

2.8 Identification:

Each shipping pallet of Criblock members is identified by a tag bearing the manufacturer's name (Retaining Walls Company) and address, the product designation (i.e., Criblock), and the name of the quality control agency (Professional Service Industries).

3.0 EVIDENCE SUBMITTED

Descriptive literature and calculations.

4.0 FINDINGS

That the Criblock Retaining Walls described in this report comply with the 1997 *Uniform Building Code*[™], subject to the following conditions:

- 4.1 **The walls are identified and installed in accordance with this report and the manufacturer's instructions.**
- 4.2 **Special inspection is provided during wall erection and backfilling in accordance with Section 2.7 of this report.**
- 4.3 **Structural calculations are submitted to the building official for approval.**
- 4.4 **A soils investigation report as noted in Section 1804 of the code is submitted to the building official, and addresses soil properties (unit density and soil friction angle for an anticipated range of normal pressures) for backfill soils, retained excavation soils and foundation soils, as applicable. Lateral loads must be determined using accepted geotechnical engineering procedures appropriate for the soil and geometric conditions specified for the wall, and must address the applicability of the Criblock system in seismically active areas.**
- 4.5 **Installation is limited to areas outside ground water, unless appropriate soils and engineering analysis reports are submitted to the building official for approval.**
- 4.6 **Criblock wall components are fabricated at 1025 Grand Avenue, in San Marcos, California, with follow-up quality control inspections by Professional Service Industries (NER-QA231).**

The report is subject to re-examination in one year.

NOTES TO TABLES

For **SI**: 1 foot = 304.8 mm, 1 psf = 47.88 Pa, 1 psf/ft. = 157 Pa/m.

EFP = Equivalent fluid pressure, psf/ft. (Pa/m).

X:1 Slope: Slope of retained soil behind wall.

Level + 2': Height of level, retained soil behind wall, feet (mm).

Sliding

Coefficient: Coefficient of sliding for soil mass.

Total Height: Overall height of retaining wall, feet (mm).

H1, H2, H3, H4: Height of cribwall depth over subsequent depth, feet (mm). The sum of H's is total height.

Bearing pressure: Downward pressure extended by wall on soil, psf (Pa).

TABLE 1—ALLOWABLE HEIGHTS FOR 4.5-FOOT-LONG HEADERS

2:1 SLOPE / 4.5' HEADERS					
EFP = 45, SLIDING COEFF = .4					
TOTAL HEIGHT	H1	H2	H3	H4	MAX. BEARING PRESSURE (PSF)
6'	6'				1771
8'	8'				2137
10'	8'	2'			1903
12'	8'	4'			2332
14'	8'	6'			2694
16'	8'	8'			2891
18'	8'	8'	2'		2453
20'	8'	8'	4'		2796
22'	8'	8'	4'	2'	3135
24'	8'	8'	4'	4'	3465
26'	8'	8'	4'	6'	3761
28'	8'	8'	4'	8'	4015

2:1 SLOPE / 4.5' HEADERS					
EFP = 55, SLIDING COEFF = .4					
TOTAL HEIGHT	H1	H2	H3	H4	MAX. BEARING PRESSURE (PSF)
6'	6'				1716
8'	6'	2'			1808
10'	6'	4'			2252
12'	6'	6'			2593
14'	6'	6'	2'		2491
16'	6'	6'	2'	2'	3164
18'	6'	6'	2'	4'	3564
20'	6'	6'	2'	6'	3934

2:1 SLOPE / 4.5' HEADERS					
EFP = 45, SLIDING COEFF = .5					
TOTAL HEIGHT	H1	H2	H3	H4	MAX. BEARING PRESSURE (PSF)
6'	6'				1771
8'	8'				2137
10'	10'				2255
12'	12'				2015
14'	12'	2'			2013
16'	12'	4'			2448
18'	12'	6'			3002
20'	12'	8'			3742
22'	12'	8'	2'		3806
24'	12'	8'	4'		4348
26'	12'	8'	6'		4977
28'	12'	8'	8'		5704
30'	12'	8'	8'	2'	5667
32'	12'	8'	8'	4'	6268
34'	12'	8'	8'	6'	6937

2:1 SLOPE / 4.5' HEADERS					
EFP = 55, SLIDING COEFF = .5					
TOTAL HEIGHT	H1	H2	H3	H4	MAX. BEARING PRESSURE (PSF)
6'	6'				1716
8'	8'				1950
10'	8'	2'			1837
12'	8'	4'			2188
14'	8'	6'			2434
16'	8'	8'			2505
18'	8'	8'	2'		2880
20'	8'	8'	4'		3369
22'	8'	8'	4'	2'	3409
24'	8'	8'	4'	4'	3840
26'	8'	8'	4'	6'	4335
28'	8'	8'	4'	8'	4900

2:1 SLOPE / 4.5' HEADERS					
EFP = 45, SLIDING COEFF = .6					
TOTAL HEIGHT	H1	H2	H3	H4	MAX. BEARING PRESSURE (PSF)
6'	6'				1771
8'	8'				2137
10'	10'				2255
12'	12'				2015
14'	12'	2'			2012
16'	12'	4'			2448
18'	12'	6'			3002
20'	12'	8'			3742
22'	12'	10'			4770
24'	12'	10'	2'		4658
26'	12'	10'	4'		5318
28'	12'	10'	6'		6077
30'	12'	10'	8'		6946
32'	12'	10'	8'	2'	6579
34'	12'	10'	8'	4'	7273

2:1 SLOPE / 4.5' HEADERS					
EFP = 55, SLIDING COEFF = .6					
TOTAL HEIGHT	H1	H2	H3	H4	MAX. BEARING PRESSURE (PSF)
6'	6'				1716
8'	8'				1950
10'	10'				1838
12'	12'				2874
14'	12'	2'			2403
16'	12'	4'			3021
18'	12'	6'			3806
20'	12'	8'			4839
22'	12'	8'	2'		4553
24'	12'	8'	4'		5301
26'	12'	8'	6'		6170
28'	12'	8'	6'	2'	5782
30'	12'	8'	6'	4'	6491
32'	12'	8'	6'	6'	7287
34'	12'	8'	6'	8'	8178

TABLE 1—ALLOWABLE HEIGHTS FOR 4.5-FOOT-LONG HEADERS—(Continued)

1.5:1 SLOPE / 4.5' HEADERS					
EFP = 55, SLIDING COEFF = .4					
TOTAL HEIGHT	H1	H2	H3	H4	MAX. BEARING PRESSURE (PSF)
6'	6'				1672
8'	6'	2'			1775
10'	6'	4'			2165
12'	6'	4'	2'		2417
14'	6'	4'	2'	2'	3064
16'	6'	4'	2'	4'	3445

1.5:1 SLOPE / 4.5' HEADERS					
EFP = 65, SLIDING COEFF = .4					
TOTAL HEIGHT	H1	H2	H3	H4	MAX. BEARING PRESSURE (PSF)
4'	4'				1280
6'	4'	2'			1694
8'	4'	2'	2'		2328

1.5:1 SLOPE / 4.5' HEADERS					
EFP = 55, SLIDING COEFF = .5					
TOTAL HEIGHT	H1	H2	H3	H4	MAX. BEARING PRESSURE (PSF)
6'	6'				1672
8'	8'				1828
10'	8'	2'			1749
12'	8'	4'			2041
14'	8'	6'			2232
16'	8'	6'	2'		2568
18'	8'	6'	4'		3025
20'	8'	6'	4'	2'	3258
22'	8'	6'	4'	4'	3692
24'	8'	6'	4'	6'	4187

1.5:1 SLOPE / 4.5' HEADERS					
EFP = 65, SLIDING COEFF = .5					
TOTAL HEIGHT	H1	H2	H3	H4	MAX. BEARING PRESSURE (PSF)
6'	6'				1600
8'	6'	2'			1744
10'	6'	4'			2074
12'	6'	4'	2'		2344
14'	6'	4'	4'		2633
16'	6'	4'	4'	2'	2924

1.5:1 SLOPE / 4.5' HEADERS					
EFP = 55, SLIDING COEFF = .6					
TOTAL HEIGHT	H1	H2	H3	H4	MAX. BEARING PRESSURE (PSF)
6'	6'				1672
8'	8'				1828
10'	10'				1827
12'	10'	2'			1882
14'	10'	4'			2389
16'	10'	6'			3044
18'	10'	8'			3961
20'	10'	8'	2'		4061
22'	10'	8'	4'		4747
24'	10'	8'	6'		5546
26'	10'	8'	8'		6474
28'	10'	8'	8'	2'	6413
30'	10'	8'	8'	4'	7201
32'	10'	8'	8'	6'	8081

1.5:1 SLOPE / 4.5' HEADERS					
EFP = 65, SLIDING COEFF = .6					
TOTAL HEIGHT	H1	H2	H3	H4	MAX. BEARING PRESSURE (PSF)
6'	6'				1600
8'	8'				1607
10'	8'	2'			1656
12'	8'	4'			1948
14'	8'	6'			2585
16'	8'	6'	2'		2940
18'	8'	6'	4'		3532
20'	8'	6'	6'		4240
22'	8'	6'	6'	2'	4491
24'	8'	6'	6'	4'	5145

TABLE 1—ALLOWABLE HEIGHTS FOR 4.5-FOOT-LONG HEADERS—(Continued)

LEVEL + 2' / 4.5' HEADERS					
EFP = 35, SLIDING COEFF = .4					
TOTAL HEIGHT	H1	H2	H3	H4	MAX. BEARING PRESSURE (PSF)
6'	6'				1468
8'	8'				1790
10'	10'				1917
12'	10'	2'			1790
14'	10'	4'			2196
16'	10'	6'			2556
18'	10'	8'			2795
20'	10'	10'			2891
22'	10'	10'	2'		3050
24'	10'	10'	4'		3384
26'	10'	10'	6'		3771
28'	10'	10'	8'		4218
30'	10'	10'	10'		4735
32'	10'	10'	10'	2'	4961
34'	10'	10'	10'	4'	5379

LEVEL + 2' / 4.5' HEADERS					
EFP = 45, SLIDING COEFF = .4					
TOTAL HEIGHT	H1	H2	H3	H4	MAX. BEARING PRESSURE (PSF)
6'	6'				1358
8'	6'	2'			1602
10'	6'	4'			2078
12'	6'	6'			2487
14'	6'	8'			2792
16'	6'	10'			2980
18'	6'	10'	2'		2377
20'	6'	10'	4'		2700
22'	6'	10'	6'		2998
24'	6'	10'	6'	2'	3109
26'	6'	10'	6'	4'	3449
28'	6'	10'	6'	6'	3755
30'	6'	10'	6'	8'	4030
32'					
34'					

LEVEL + 2' / 4.5' HEADERS					
EFP = 35, SLIDING COEFF = .5					
TOTAL HEIGHT	H1	H2	H3	H4	MAX. BEARING PRESSURE (PSF)
6'	6'				1468
8'	8'				1790
10'	10'				1917
12'	12'				2064
14'	14'				3268
16'	14'	2'			2603
18'	14'	4'			3069
20'	14'	6'			3635
22'	14'	8'			4320
24'	14'	10'			5243
26'	14'	12'			6404
28'	14'	12'	2'		5675
30'	14'	12'	4'		6347
32'	14'	12'	6'		7102
34'	14'	12'	8'		7947

LEVEL + 2' / 4.5' HEADERS					
EFP = 45, SLIDING COEFF = .5					
TOTAL HEIGHT	H1	H2	H3	H4	MAX. BEARING PRESSURE (PSF)
6'	6'				1358
8'	8'				1502
10'	10'				1950
12'	10'	2'			1618
14'	10'	4'			1972
16'	10'	6'			2429
18'	10'	8'			3084
20'	10'	10'			3966
22'	10'	10'	2'		3774
24'	10'	10'	4'		4310
26'	10'	10'	6'		4932
28'	10'	10'	8'		5651
30'	10'	10'	8'	2'	5223
32'	10'	10'	8'	4'	5769
34'	10'	10'	8'	6'	6380

LEVEL + 2' / 4.5' HEADERS					
EFP = 35, SLIDING COEFF = .6					
TOTAL HEIGHT	H1	H2	H3	H4	MAX. BEARING PRESSURE (PSF)
6'	6'				1468
8'	8'				1790
10'	10'				1917
12'	12'				2064
14'	14'				3268
16'	14'	2'			2603
18'	14'	4'			3069
20'	14'	6'			3635
22'	14'	8'			4320
24'	14'	10'			5243
26'	14'	12'			6404
28'	14'	12'	2'		5675
30'	14'	12'	4'		6347
32'	14'	12'	6'		7102
34'	14'	12'	8'		7947

LEVEL + 2' / 4.5' HEADERS					
EFP = 45, SLIDING COEFF = .6					
TOTAL HEIGHT	H1	H2	H3	H4	MAX. BEARING PRESSURE (PSF)
6'	6'				1359
8'	8'				1502
10'	10'				1950
12'	12'				3231
14'	12'	2'			2335
16'	12'	4'			2856
18'	12'	6'			3505
20'	12'	8'			4330
22'	12'	10'			5474
24'	12'	10'	2'		4738
26'	12'	10'	4'		5412
28'	12'	10'	6'		6184
30'	12'	10'	8'		7066
32'	12'	10'	10'		8070
34'	12'	10'	10'	2'	7300

For SI: 1 foot = 304.8 mm, 1 psf = 0.0479 kN/m².

TABLE 2—ALLOWABLE HEIGHTS FOR 5-FOOT-LONG HEADERS

2:1 SLOPE / 5.0' HEADERS					
EFP = 45, SLIDING COEFF = .4					
TOTAL HEIGHT	H1	H2	H3	H4	MAX. BEARING PRESSURE (PSF)
6'	6'				1824
8'	8'				2243
10'	10'				2475
12'	10'	2'			2084
14'	10'	4'			2478
16'	10'	6'			2816
18'	10'	8'			3027
20'	10'	8'	2'		2751
22'	10'	8'	4'		3089
24'	10'	8'	6'		3481
26'	10'	8'	6'	2'	3695
28'	10'	8'	6'	4'	4033
30'	10'	8'	6'	6'	4411

2:1 SLOPE / 5.0' HEADERS					
EFP = 55, SLIDING COEFF = .4					
TOTAL HEIGHT	H1	H2	H3	H4	MAX. BEARING PRESSURE (PSF)
6'	6'				1788
8'	8'				2099
10'	8'	2'			2018
12'	8'	4'			2418
14'	8'	4'	2'		2769
16'	8'	4'	4'		3167
18'	8'	4'	6'		3528
20'	8'	4'	6'	2'	3504
22'	8'	4'	6'	4'	3859

2:1 SLOPE / 5.0' HEADERS					
EFP = 45, SLIDING COEFF = .5					
TOTAL HEIGHT	H1	H2	H3	H4	MAX. BEARING PRESSURE (PSF)
6'	6'				1824
8'	8'				2243
10'	10'				2475
12'	12'				2433
14'	14'				2641
16'	14'	2'			2428
18'	14'	4'			2889
20'	14'	6'			3457
22'	14'	8'			4152
24'	14'	8'	2'		4067
26'	14'	8'	4'		4575
28'	14'	8'	6'		5157
30'	14'	8'	8'		5820
32'	14'	8'	8'	2'	5718
34'	14'	8'	8'	4'	6252

2:1 SLOPE / 5.0' HEADERS					
EFP = 55, SLIDING COEFF = .5					
TOTAL HEIGHT	H1	H2	H3	H4	MAX. BEARING PRESSURE (PSF)
6'	6'				1788
8'	8'				2099
10'	10'				2145
12'	10'	2'			1977
14'	10'	4'			2281
16'	10'	6'			2497
18'	10'	6'	2'		2612
20'	10'	6'	4'		2965
22'	10'	6'	6'	2'	3421
24'	10'	6'	8'	4'	3959
26'	10'	6'	8'	6'	4313
28'	10'	6'	8'	6'	4789
30'	10'	6'	8'	6'	5324

2:1 SLOPE / 5.0' HEADERS					
EFP = 45, SLIDING COEFF = .6					
TOTAL HEIGHT	H1	H2	H3	H4	MAX. BEARING PRESSURE (PSF)
6'	6'				1824
8'	8'				2243
10'	10'				2475
12'	12'				2433
14'	14'				2641
16'	16'				4222
18'	16'	2'			3198
20'	16'	4'			3805
22'	16'	6'			4539
24'	16'	8'			5418
26'	16'	8'	2'		4877
28'	16'	8'	4'		5487
30'	16'	8'	6'		6179
32'	16'	8'	8'		6961
34'	16'	8'	10'		7843

2:1 SLOPE / 5.0' HEADERS					
EFP = 55, SLIDING COEFF = .6					
TOTAL HEIGHT	H1	H2	H3	H4	MAX. BEARING PRESSURE (PSF)
6'	6'				1788
8'	8'				2099
10'	10'				2145
12'	12'				2289
14'	12'	2'			2128
16'	12'	4'			2614
18'	12'	6'			3226
20'	12'	8'			4007
22'	12'	10'			5104
24'	12'	10'	2'		4846
26'	12'	10'	4'		5548
28'	12'	10'	6'		6352
30'	12'	10'	8'		7270
32'	12'	10'	8'	2'	6812
34'	12'	10'	8'	4'	7542

TABLE 2—ALLOWABLE HEIGHTS FOR 5-FOOT-LONG HEADERS—(Continued)

1.5:1 SLOPE / 5.0' HEADERS					
EFP = 55, SLIDING COEFF = .4					
TOTAL HEIGHT	H1	H2	H3	H4	MAX. BEARING PRESSURE (PSF)
6'	6'				1758
8'	6'	2'			1928
10'	6'	4'			2344
12'	6'	4'	2'		2680
14'	6'	4'	4'		3068
16'	6'	4'	4'	2'	3418
18'	6'	4'	4'	4'	3792

1.5:1 SLOPE / 5.0' HEADERS					
EFP = 65, SLIDING COEFF = .4					
TOTAL HEIGHT	H1	H2	H3	H4	MAX. BEARING PRESSURE (PSF)
4'	4'				1347
6'	4'	2'			1834
8'	4'	2'	2'		2546

1.5:1 SLOPE / 5.0' HEADERS					
EFP = 55, SLIDING COEFF = .5					
TOTAL HEIGHT	H1	H2	H3	H4	MAX. BEARING PRESSURE (PSF)
6'	6'				1758
8'	8'				1993
10'	8'	2'			1947
12'	8'	4'			2288
14'	8'	6'			2554
16'	8'	8'			2640
18'	8'	8'	2'		2968
20'	8'	8'	4'		3430
22'	8'	8'	4'	2'	3585
24'	8'	8'	4'	4'	4005
26'	8'	8'	4'	6'	4478
28'	8'	8'	4'	8'	5009

1.5:1 SLOPE / 5.0' HEADERS					
EFP = 65, SLIDING COEFF = .5					
TOTAL HEIGHT	H1	H2	H3	H4	MAX. BEARING PRESSURE (PSF)
6'	6'				1704
8'	6'	2'			1913
10'	6'	4'			2278
12'	6'	6'			2551
14'	6'	6'	2'		2562
16'	6'	6'	2'	2'	3332
18'	6'	6'	2'	4'	3649
20'	6'	6'	2'	6'	3928

1.5:1 SLOPE / 5.0' HEADERS					
EFP = 55, SLIDING COEFF = .6					
TOTAL HEIGHT	H1	H2	H3	H4	MAX. BEARING PRESSURE (PSF)
6'	6'				1758
8'	8'				1993
10'	10'				1939
12'	12'				2696
14'	12'	2'			2384
16'	12'	4'			2939
18'	12'	6'			3629
20'	12'	8'			4478
22'	12'	8'	2'		4454
24'	12'	8'	4'		5117
26'	12'	8'	6'		5877
28'	12'	8'	8'		6746
30'	12'	8'	8'	2'	6596
32'	12'	8'	8'	4'	7318
34'	12'	8'	8'	6'	8115

1.5:1 SLOPE / 5.0' HEADERS					
EFP = 65, SLIDING COEFF = .6					
TOTAL HEIGHT	H1	H2	H3	H4	MAX. BEARING PRESSURE (PSF)
6'	6'				1704
8'	8'				1815
10'	10'				2020
12'	10'	2'			1982
14'	10'	4'			2529
16'	10'	6'			3225
18'	10'	6'	2'		3397
20'	10'	6'	4'		3995
22'	10'	6'	6'		4694
24'	10'	6'	6'	2'	4833
26'	10'	6'	6'	4'	5457
28'	10'	6'	6'	6'	6158

TABLE 2—ALLOWABLE HEIGHTS FOR 5-FOOT-LONG HEADERS—(Continued)

LEVEL + 2' / 5.0' HEADERS					
EFP = 35, SLIDING COEFF = .4					
TOTAL HEIGHT	H1	H2	H3	H4	MAX. BEARING PRESSURE (PSF)
6'	6'				1542
8'	8'				1948
10'	10'				2220
12'	12'				2291
14'	12'	2'			1997
16'	12'	4'			2397
18'	12'	6'			2756
20'	12'	8'			3051
22'	12'	10'			3184
24'	12'	12'			3558
26'	12'	12'	2'		3791
28'	12'	12'	4'		4162
30'	12'	12'	6'		4581
32'	12'	12'	8'		5056
34'	12'	12'	10'		5593

LEVEL + 2' / 5.0' HEADERS					
EFP = 45, SLIDING COEFF = .4					
TOTAL HEIGHT	H1	H2	H3	H4	MAX. BEARING PRESSURE (PSF)
6'	6'				1473
8'	8'				1745
10'	8'	2'			1859
12'	8'	4'			2318
14'	8'	6'			2741
16'	8'	8'			3039
18'	8'	10'			3233
20'	8'	10'	2'		2703
22'	8'	10'	4'		3050
24'	8'	10'	6'		3357
26'	8'	10'	8'		3615
28'	8'	10'	8'	2'	3627
30'	8'	10'	8'	4'	3936
32'	8'	10'	8'	6'	4283
34'	8'	10'	8'	8'	4674

LEVEL + 2' / 5.0' HEADERS					
EFP = 35, SLIDING COEFF = .5					
TOTAL HEIGHT	H1	H2	H3	H4	MAX. BEARING PRESSURE (PSF)
6'	6'				1542
8'	8'				1948
10'	10'				2220
12'	12'				2291
14'	14'				2365
16'	16'				3589
18'	16'	2'			2856
20'	16'	4'			3300
22'	16'	6'			3827
24'	16'	8'			4455
26'	16'	10'			5218
28'	16'	12'			6244
30'	16'	12'	2'		5480
32'	16'	12'	4'		6045
34'	16'	12'	6'		6675

LEVEL + 2' / 5.0' HEADERS					
EFP = 45, SLIDING COEFF = .5					
TOTAL HEIGHT	H1	H2	H3	H4	MAX. BEARING PRESSURE (PSF)
6'	6'				1473
8'	8'				1745
10'	10'				1798
12'	12'				2400
14'	12'	2'			1923
16'	12'	4'			2288
18'	12'	6'			2743
20'	12'	8'			3319
22'	12'	10'			4141
24'	12'	10'	2'		3836
26'	12'	10'	4'		4309
28'	12'	10'	6'		4850
30'	12'	10'	8'		5471
32'	12'	10'	10'		6178
34'	12'	10'	10'	2'	5863

LEVEL + 2' / 5.0' HEADERS					
EFP = 35, SLIDING COEFF = .6					
TOTAL HEIGHT	H1	H2	H3	H4	MAX. BEARING PRESSURE (PSF)
6'	6'				1542
8'	8'				1948
10'	10'				2220
12'	12'				2291
14'	14'				2365
16'	16'				3589
18'	16'	2'			2856
20'	16'	4'			3300
22'	16'	6'			3827
24'	16'	8'			4455
26'	16'	10'			5218
28'	16'	12'			6244
30'	16'	12'	2'		5480
32'	16'	12'	4'		6045
34'	16'	12'	6'		6675

LEVEL + 2' / 5.0' HEADERS					
EFP = 45, SLIDING COEFF = .6					
TOTAL HEIGHT	H1	H2	H3	H4	MAX. BEARING PRESSURE (PSF)
6'	6'				1473
8'	8'				1745
10'	10'				1798
12'	12'				2400
14'	12'	2'			1923
16'	12'	4'			2288
18'	12'	6'			2743
20'	12'	8'			3319
22'	12'	10'			4141
24'	12'	12'			5153
26'	12'	12'	2'		4710
28'	12'	12'	4'		5296
30'	12'	12'	6'		5961
32'	12'	12'	8'		6714
34'	12'	12'	10'		7564

For SI: 1 foot = 304.8 mm, 1 psf = 0.0479 kN/m².

FRONT STRETCHER 125 LBS.

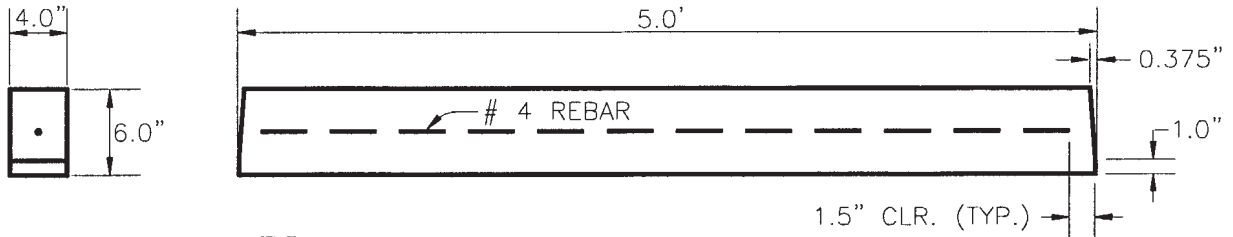

BACK STRETCHER 95 LBS.

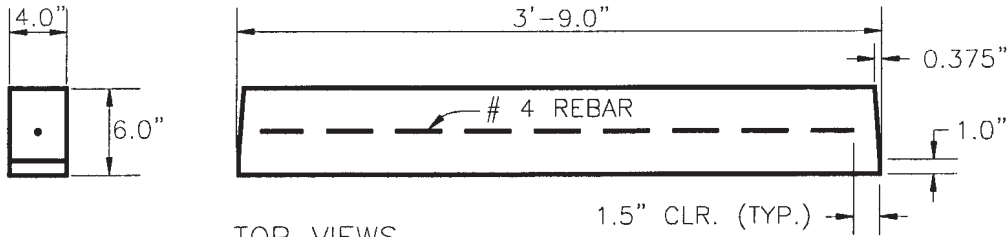

TOP VIEWS

HEADER 115 LBS. (135 LBS.)

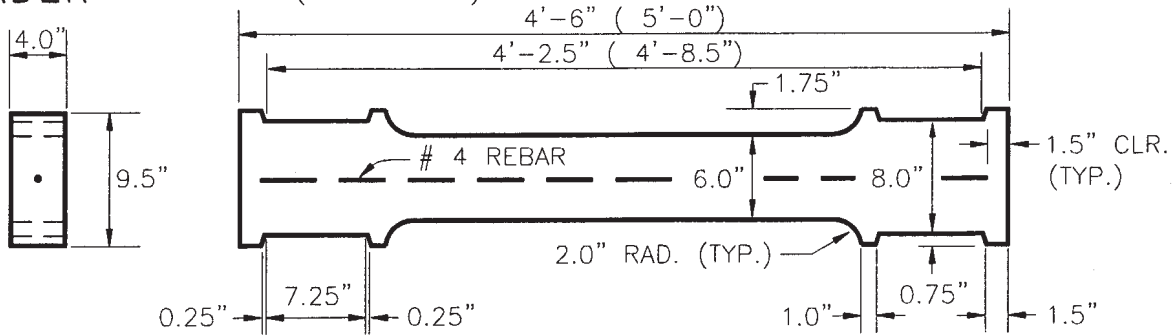

FALSE HEADER 30 LBS.

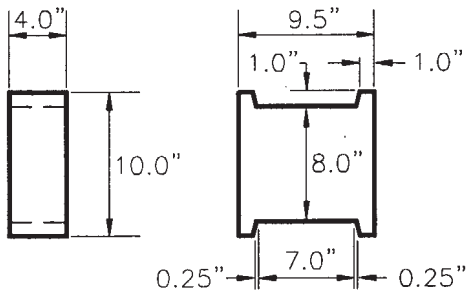

END VIEWS

SIDE VIEWS

NOTES:

1. STRENGTH OF MATERIALS
 - A. COMPRESSIVE STRENGTH OF CONCRETE
 $f'_c = 3250 \text{ PSI}$
 - B. YIELD STRENGTH OF STEEL
 $f_y = 60,000 \text{ PSI}$

CRIBLOCK™ RETAINING WALL MEMBERS DIMENSIONS

For SI: 1 inch = 25.4 mm, 1 foot = 304.8 mm, 1 psi = 6.89 kPa, 1 pound = 0.45 kg.

FIGURE 1

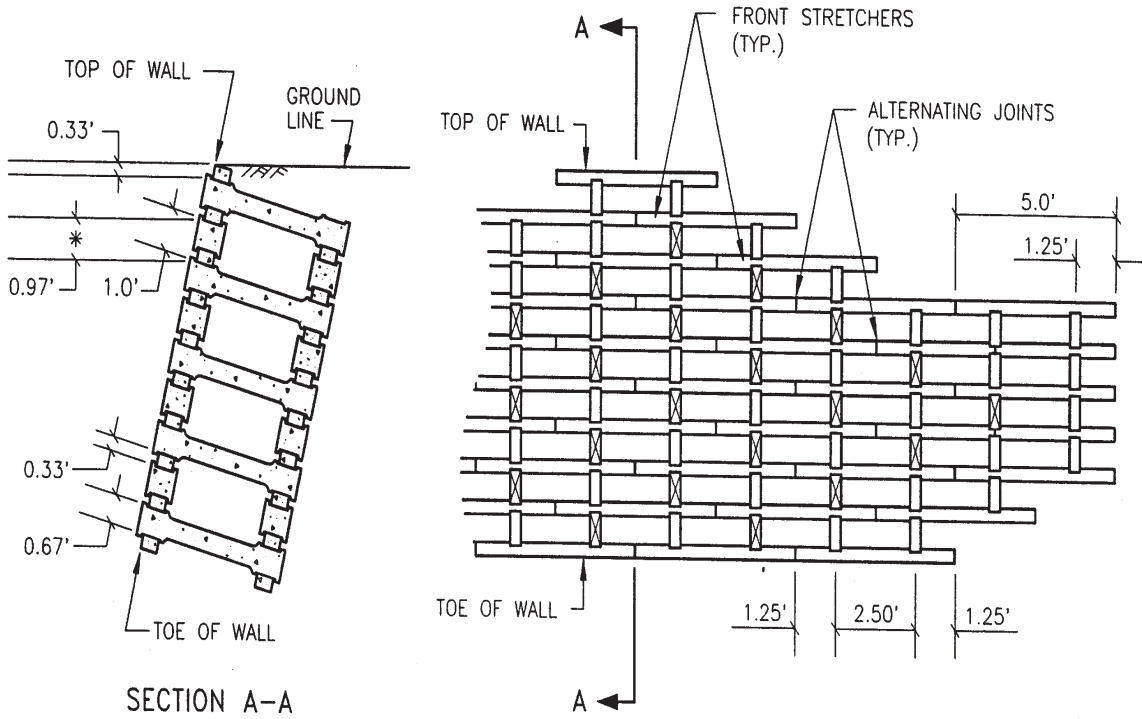

* = BATTERED VERTICAL INCREMENT 0.97' FOR STD. 1:4 BATTER.

NOTE: "X" MARKS FALSE HEADERS. ALL OTHERS ARE FULL HEADERS.

TYPICAL PROFILE
NO SCALE

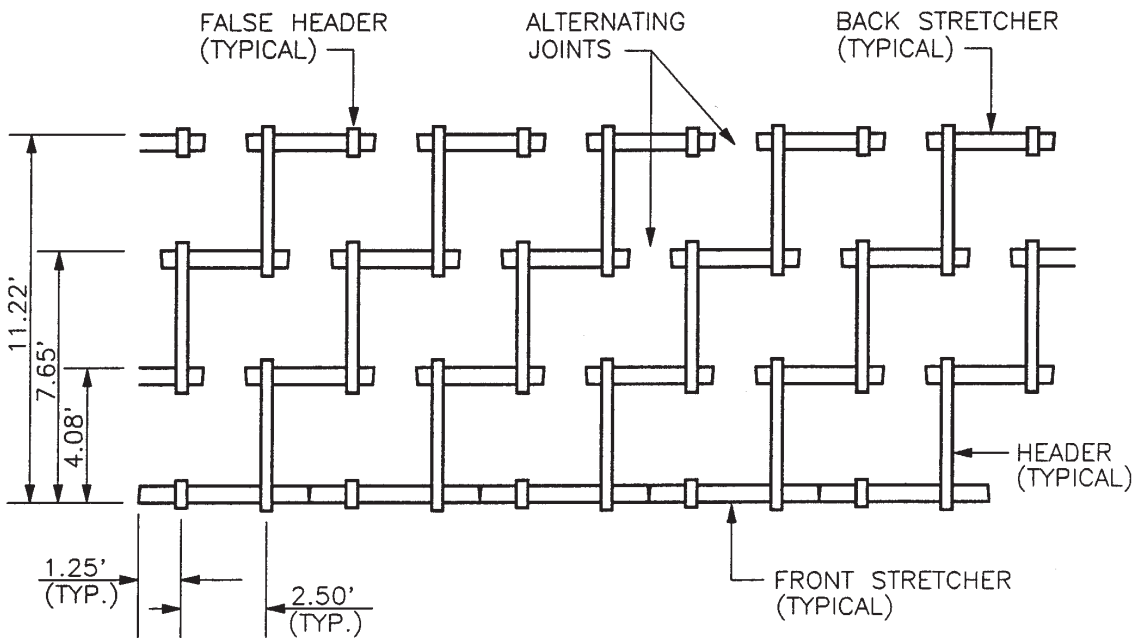

TYPICAL TRIPLE DEPTH
PLAN VIEW BASE COURSE
4.5' HEADER

NO SCALE

For SI: 1 foot = 304.8 mm.

FIGURE 2

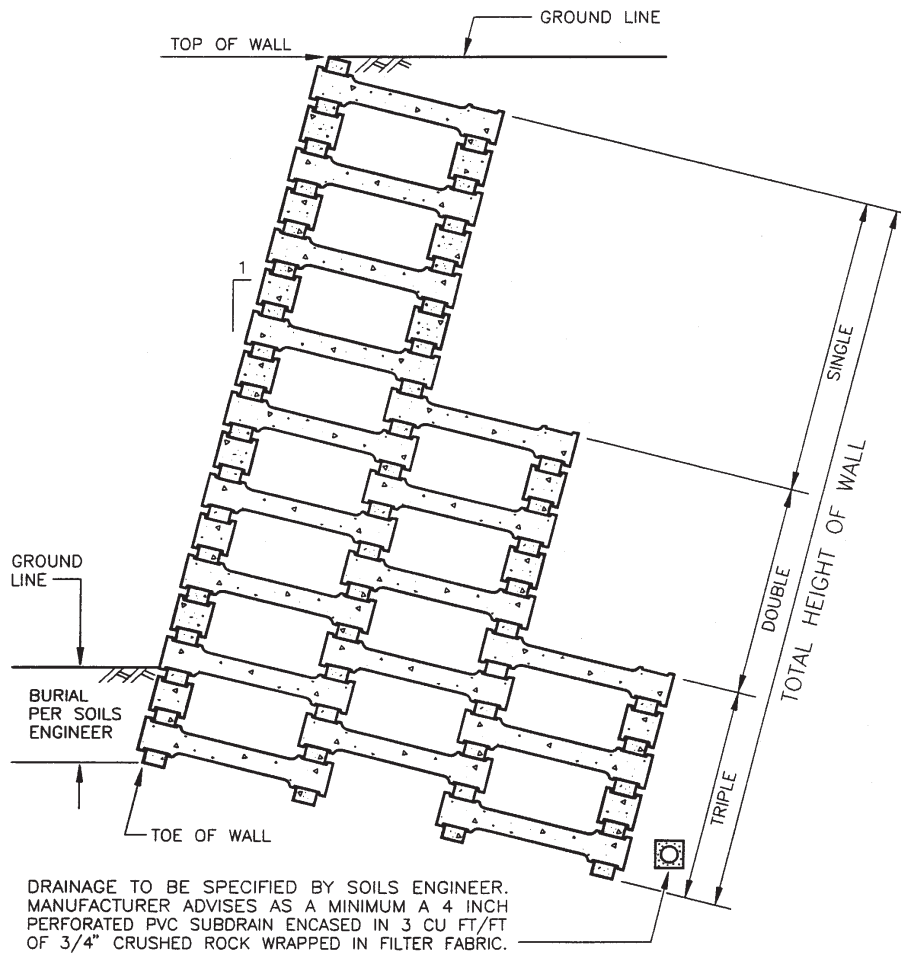

**TYPICAL TRIPLE DEPTH X-SECTION
LEVEL BACKFILL**
NO SCALE

For SI: 1 inch = 25.4 mm, 1 foot³/foot = 0.09 m³/m.

FIGURE 3